

Aqua Advanced contains the following items for installation and commissioning. We recommend you check the list to ensure all items are included with the delivery of your tank. Remove tank lid to access:

## PRE INSTALLED PARTS

1. Water treatment system assembly, comprising a 4,000 litre polymer tank, polymer chambers, polymer lid and polymer inspection lid
2. Bioball clarification media
3. Bioblock aeration media
4. PVC bio-media
5. Pump out access pipe

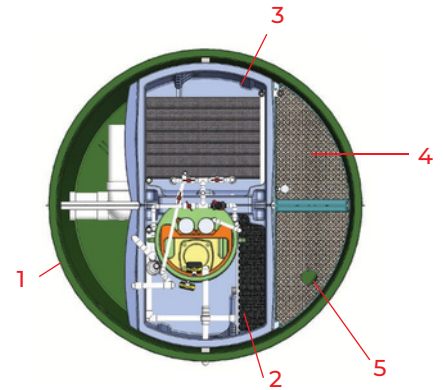

**LOOSE ITEMS/ PARTS (you will use during installation, electrical connection and commissioning. Parts are numbered for easy reference in the instructions)**

1. Polymer anchor rope (28m)
2. Submersible pump (x1)
3. Anchor pipes - 1.25m x  $\varnothing$ 100mm PVC pipe (x 4)
4. Reclaimed effluent sign (x 2)
5. Threaded Pump Fittings (x 3)
6. Flexible Coupling 100mm (x 1)
7. Discharge pipes (x3) (vertical (16a), U shaped (16b), L shape (16c))
8. non-return Valve (v1)

## PREPARATION

1. Excavate hole to 2.2m wide and required depth determined by the invert level.
2. Place gravel or sand in the bottom of the hole to a depth of roughly 5-10cm.
3. To anchor the system, cut the anchor rope into 8 equal lengths. Tie the ropes into loops passing through the pre-drilled tie-down holes. Fill pipes with loose dirt or gravel and cap or duct tape the pipe ends. Place pipe into the tie down loops.

## INSTALLATION

4. Lift system into excavated hole, aligning the inlet with the plumbing.
5. Select the correct threaded pump fitting for your pump. Use PVC solvent to glue the pump fitting and the non-return valve to each end of the straight discharge pipe. Screw the discharge pipe assembly to the outlet of the pump.
6. Place the pump into the irrigation chamber so that it sits on the pump shelf about half-way down in the chamber. Use the remaining discharge pipe pieces and elbows to connect the pump to the outlet fitting on the side of the tank.
7. Feed the power cable from the pump up into the control box through the bung with the float switch cable. Plug the pump into the power outlet of the control panel marked "EFFLUENT PUMP"

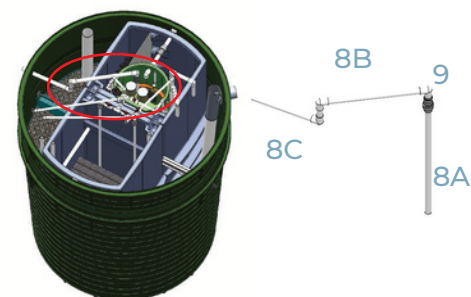
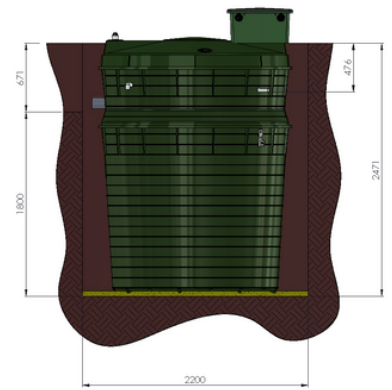

## CONTROL BOX CONNECTION/ ELECTRICALS

- Cut and remove the strap that holds the aerator inside the control box.
- Install a powered 240v GPO junction box inside the control box to provide power for the control panel. Plug control panel into the freshly installed GPO. Ensure power to the system remains off until the "COMMISSIONING THE SYSTEM" section is underway"

## COMPLETING THE INSTALLATION

- IMPORTANT:** Use fresh water to fill the pump out chamber to approximately two thirds full. This would be the point at which the float switch on the pump would activate if power was connected.
- Fill the clarification chamber with fresh water until water enters the aeration chamber. Continue to fill the system until the water has back flowed into the secondary and primary chambers. Approximately 3,000 litres of water will be required in total.

## COMMISSIONING THE SYSTEM

- Switch on the the electrical power to the system air blowers and the pump should begin operation. Ensure the pump is operating as intended, switching itself on and off. The pump must leave sufficient water in the chamber for the pump inlet to remain submerged.
- Confirm the graduated valve is set to 45 degrees, the sludge return valve is slightly open for normal operation and the two aerator valves are positioned for balanced air flow.

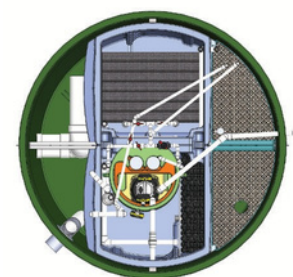
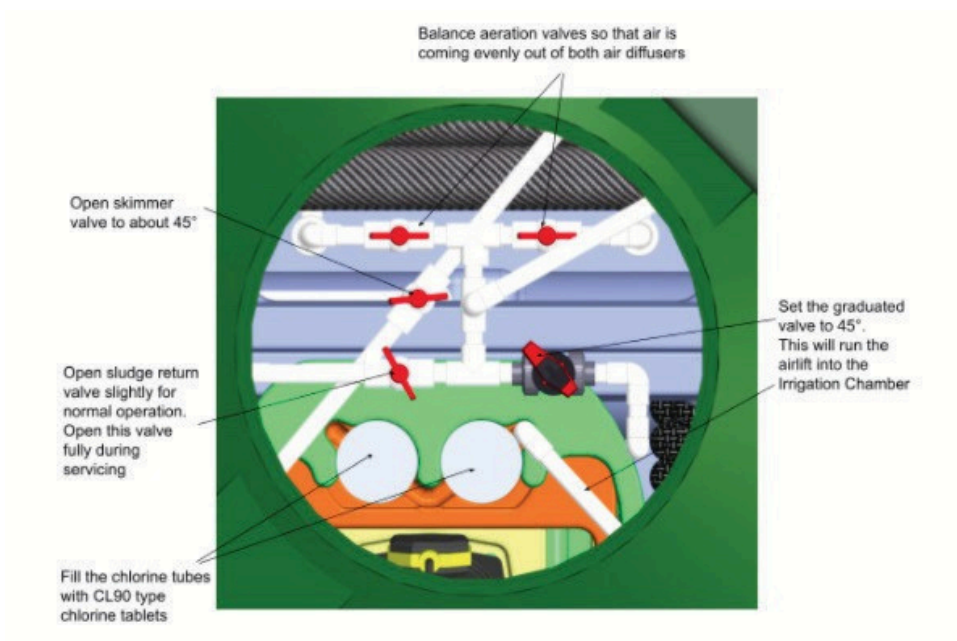

14. Keep filling the tank and unplug the submersible pump from the control panel to test the high-water level alarm. This will require another 1,000 litres of fresh water.
15. When the water level in the irrigation chamber is near the top, the alarm light on the control panel will flash. After 60 seconds, the alarm light will remain on, and the house alarm light and buzzer will sound. Stop filling the system.
16. Plug the submersible pump back into the control panel. The pump should start. If it does not, check the pump float is free.
17. The air lifter will pass water from the clarifier to the pump out chamber. When the water level in the clarifier falls, the warning light and buzzer should switch off. If they do not, check the High-Level Float is not jammed.
18. Pressing the Panel "Mute" Button only cancels the buzzer and does not cancel the light. Alarm conditions will remain until the system is back within design and operation parameters.
19. The air pump should produce bubbles in the Media Space water. Unplug the air pump from the control panel to test the low air supply alarm. It may take a few seconds before the warning light and buzzer activate as pressure in the system dissipates. Plug the air pump power cord back into the control panel. Alarm should go off automatically.
20. At this point, check all connections, inlets and outlets for any signs of leaks. If leaks are present, repair as necessary.
21. Fill the chlorine dispenser tubes with CL90 chlorine tablets
22. Fit tank access cover and secure with provided screws
23. Commence backfilling operations only when the system is filled with water AND the lid has been firmly screwed into position
24. Register the installation by scanning the QR code inside the control box. If there is no service on site, use the QR codes below to register the system. **This must be done for warranty and regulation purposes.**



INSTALLATION FORM  
SERVICE & MAINTENANCE FORM

To comply with our warranty agreement and council regulations you must complete the below forms. If you cannot access these forms using the QR code please email [info@everhard.com.au](mailto:info@everhard.com.au) for a copy.



#### INSTALLERS

Scan the QR code to access and complete the installation form.  
The form must be completed otherwise warranty is void.



#### SERVICE AGENTS

Scan the QR code to access and complete the service & maintenance form.  
The form must be completed otherwise warranty is void.