

Product Name:
45L Grease Trap Riser

EI Code:
84625, 84626

Dimensions:
84625 - 144mm H x 466mm W
84626 - 300mm H x 466mm W

Weight:
3kg

Material:
PE



Additional Information:

Minimum height of 150mm (when the unit is cut in half)

Suitable for the following products

EI CODE	PRODUCT DESCRIPTION
84010	45L Grease Trap Complete

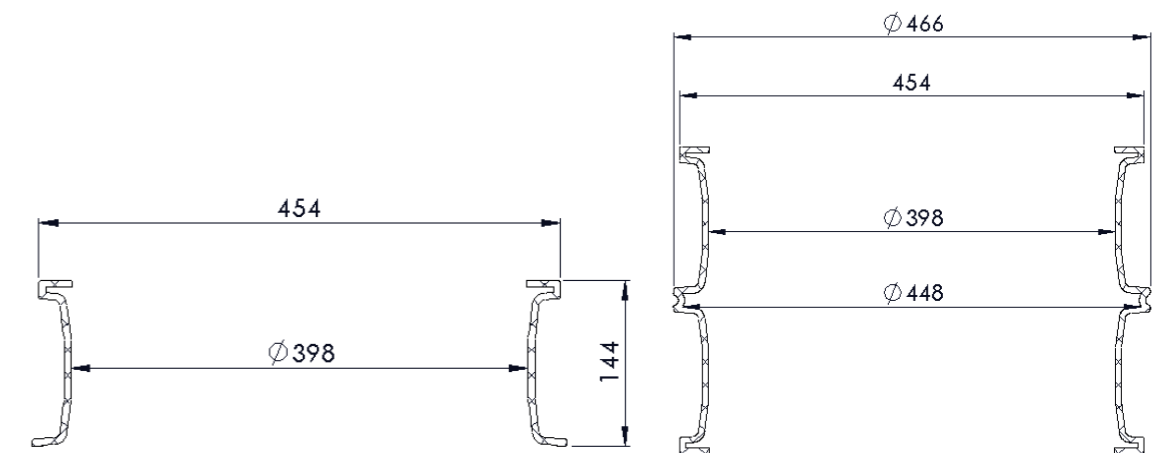
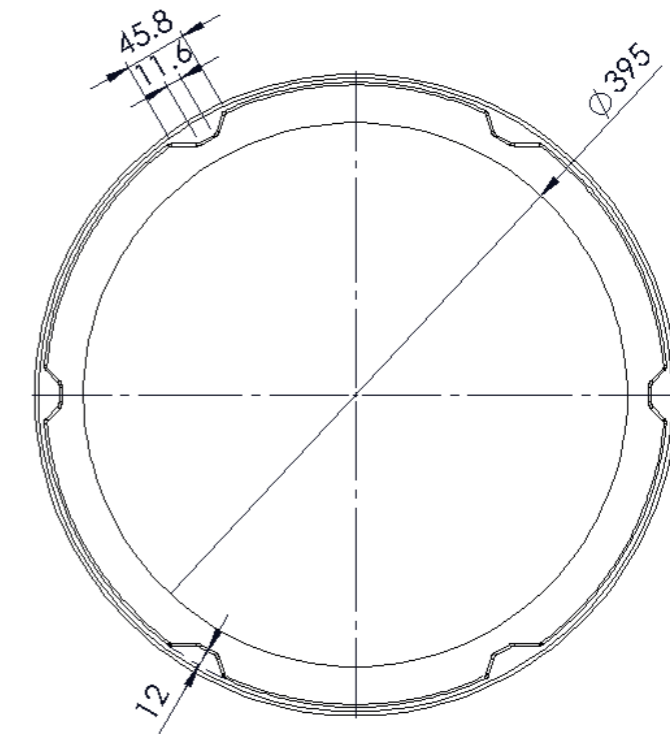

84625
144mm H

84626
300mm H

Disclaimer: All measurements are in millimetres and are subject to change without any prior notice. It is advised for this product to be installed by a professional contractor to ensure installation is correct. Further information is available at www.everhard.com.au