

**Product Name:**  
Storm Catch GPT S3

**EI Code:**  
Class A - 82310  
Class B H/P - 82312

**Dimensions:**  
453 H x 357 W

**Weight:**  
82310 - 8kg  
82312 - 11kg

**Material:**  
Grate - Galvanised Steel  
SQID - LLDPE & Stainless Steel  
Pit - PP

**Warranty:**  
10 years

**Additional Information:**

**Key features of the Storm Catch GPT S3 Range:**

- / High Flow Rate Bypass Capabilities
- / Built with 2mm Aperture Stainless Steel Mesh
- / Storage of captured dry gross pollutants
- / Strong but lightweight pits with trafficable grates
- / Multiple Sizes to suit the requirements of the application
- / Easy and simple maintenance, removal of gross pollutants greater than 2mm at the treatable flow rate <98%
- / Simple Installation
- / Treatable flow rate 25L/sec\*
- / Bypass flow rate 29L/sec\*
- / Outlet pipe size up to 225mm diameter

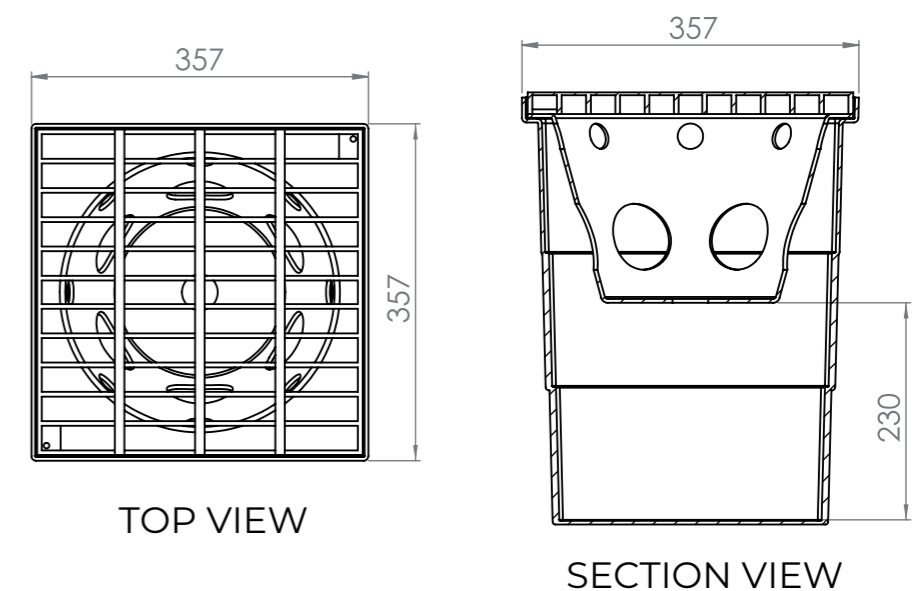
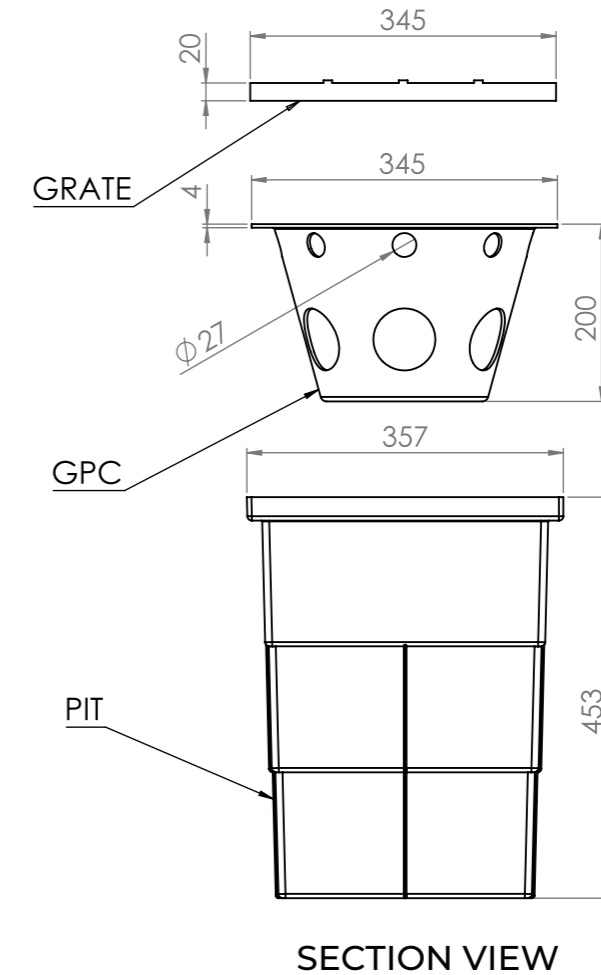
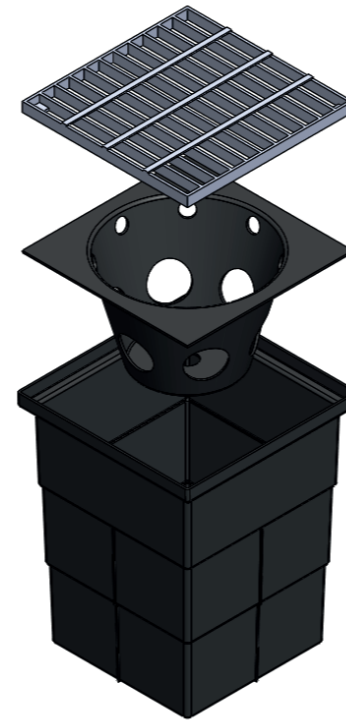

Disclaimer: All measurements are in millimetres and are subject to change without any prior notice. It is advised for this product to be installed by a professional contractor to ensure installation is correct. Further information is available at [www.everhard.com.au](http://www.everhard.com.au)  
\* Flow rates do not take into consideration any flow rate loss through the grate or size of the outlet pipes