

Product Name:
Storm Catch GPT S6

EI Code:
Class A - 82330
Class B - 82331
Class B H/P - 82332

Dimensions:
661 H x 550 W

Weight:
82330 - 39kg
82331 - 52kg
82332 - 52kg

Material:
Grate - Galvanised Steel
SQID - LLPDE & Stainless Steel
Pit - PP

Warranty:
10 years

Additional Information:

Key features of the Storm Catch GPT Range:

- / High Flow Rate Bypass Capabilities
- / Built with 2mm Aperture Stainless Steel Mesh
- / Storage of captured dry gross pollutants
- / Strong but lightweight pits with trafficable grates
- / Multiple Sizes to suit the requirements of the application
- / Easy and simple maintenance, removal of gross pollutants greater than 2mm at the treatable flow rate <98%
- / Simple Installation
- / Treatable flow rate 60L/sec*
- / Bypass flow rate 72L/sec*
- / Outlet pipe size up to 300mm diameter

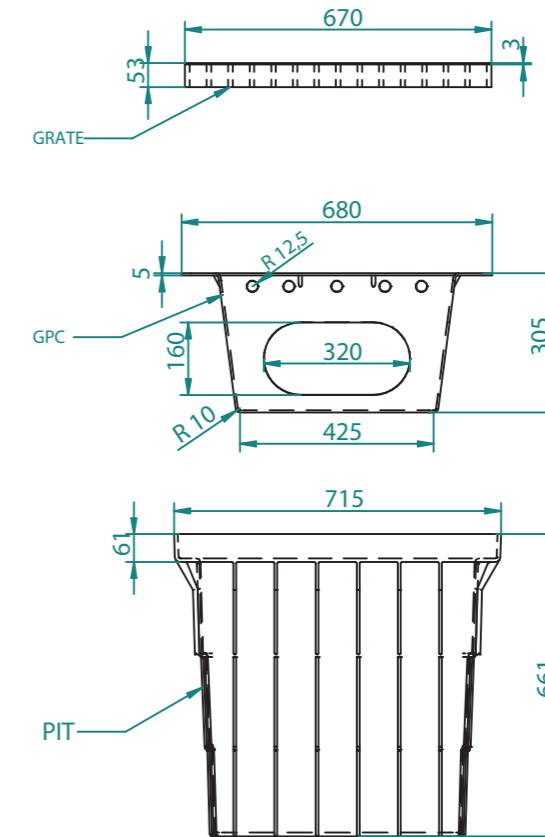
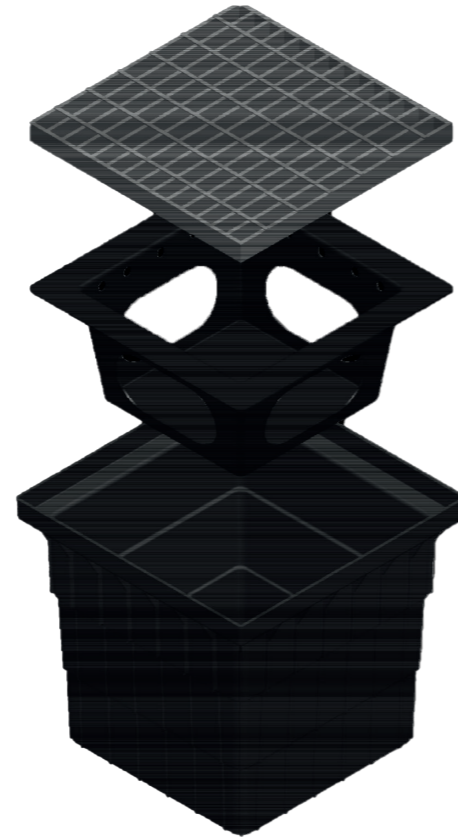

FRONT VIEW

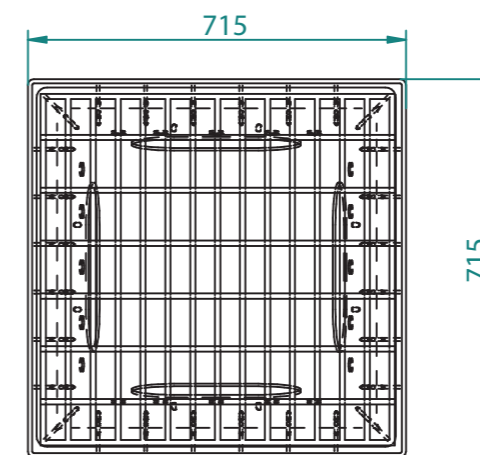

TOP VIEW

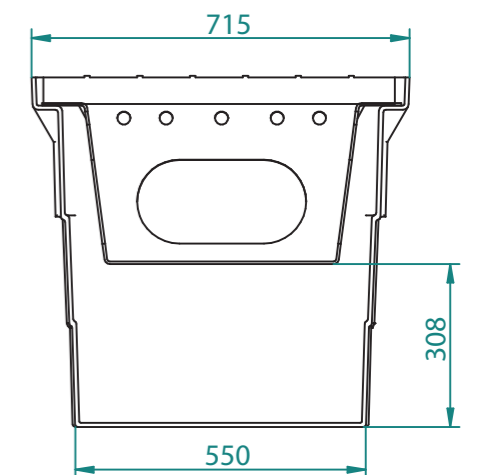

SECTION VIEW

Disclaimer: All measurements are in millimetres and are subject to change without any prior notice. It is advised for this product to be installed by a professional contractor to ensure installation is correct. Further information is available at www.everhard.com.au

* Flow rates do not take into consideration any flow rate loss through the grate or size of the outlet pipes