

SPEC PACK BATHROOM COLLECTION

SPEC SHEET



NUGLEAM ROUND ABOVE COUNTER BASIN

PRODUCT CODE:

74N0003

FEATURES:

- / Above counter basin
- / Made from vitreous china
- / 10L capacity

OVERALL DIMENSIONS:

120mm H x 360 D

WARRANTY:

5 years replacement only
1 year replacement warranty on plug
and waste

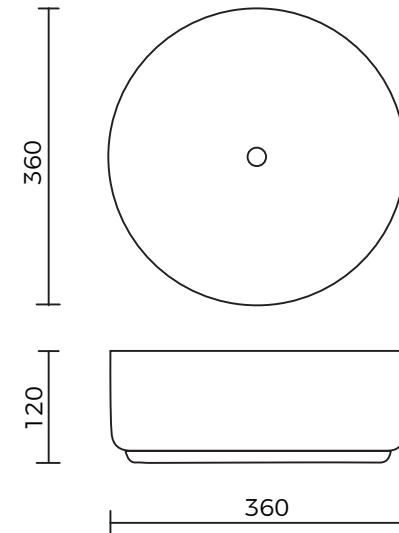

Disclaimer: All measurement are in millimetres and are solely for reference purposes. Colours have been reproduced with as much accuracy as possible. Any changes resulting from technical advance of design or colour may be made without prior notice. Tapware, accessories and appliances are for illustration purposes only. Further information on warranties is available at www.everhard.com.au

SPEC PACK BATHROOM COLLECTION

PRODUCT DRAWING

