

The easy-to-transport solution to stock watering needs, garden fish ponds, water plant propagation or any situation where a 400L watertight container is required.

- Lightweight but super tough
- UV stabilised polymer
- Food-grade HDPE
- Injection moulded
- Fitted with 40mm drain and plug

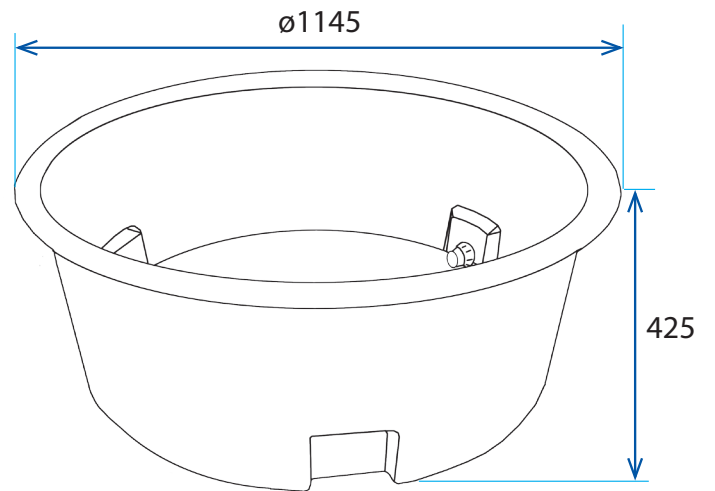

Code	Description	Weight (Kg)
87080	400L Stock Trough with Bung	16.00