

# EVERHARD GPT - CDS (NIPPER)

## INSTALLATION MANUAL

### HANDLING PACKAGED UNIT

Packaged units supplied attached to a timber pallet-type assembly should be handled using conventional fork-lift vehicles. Note that tines must be set as wide as possible to minimise damage to the fused packaging material, and should enter the pallet space as close to the upper deck timber as possible. If a packaged unit must be lifted with a web sling, caution must be exercised to avoid damage to the integrity of the wrapping material. Packaged units must not be stacked, and should be stored in locations where they are not exposed to significant levels of ultra-violet degradation. Packaged units may be loaded on trucks or other suitable vehicles, but should be secured to the head-board or other fixed structure with loading straps. When ready to install, the screws securing the tie-down straps should be removed. The unit MUST be upright and stable.

### HANDLING UNPACKAGED UNIT

The assembled unit should be kept upright and secured to the delivery pallet until required. An unpackaged complete assembly may be lifted using a webbing sling rated at not less than 1 tonne x 5 metres long. This may be fitted around underneath the pipe inlet and outlet port stubs and secured in a choked hitch. If the hitch is drawn tight the assembly may be safely moved while suspended. The hitch may be loosened to allow the unit to hang more nearly vertical for installation purposes, but should not be transported in this configuration.

### INSTALLATION CONSIDERATIONS

Location must be carefully considered during project design stages. Adequate access for cleaning and maintenance must be available, and it is strongly recommended that depths to the pipe invert are kept to an absolute minimum. The unit access port is 600mm in diameter, and access ladders cannot be fitted. Entry into the unit for any purpose is NOT recommended. Site conditions must be assessed and steps taken to eliminate risk of danger to life and property, and to reduce the risk of interrupting services. Excavations, and other site preparations, must comply with the requirements of relevant state, and local authorities. All underground services must be located and identified before any excavation work begins. It may be necessary to obtain permission to begin work, and shoring of trenching and shafts may be required.

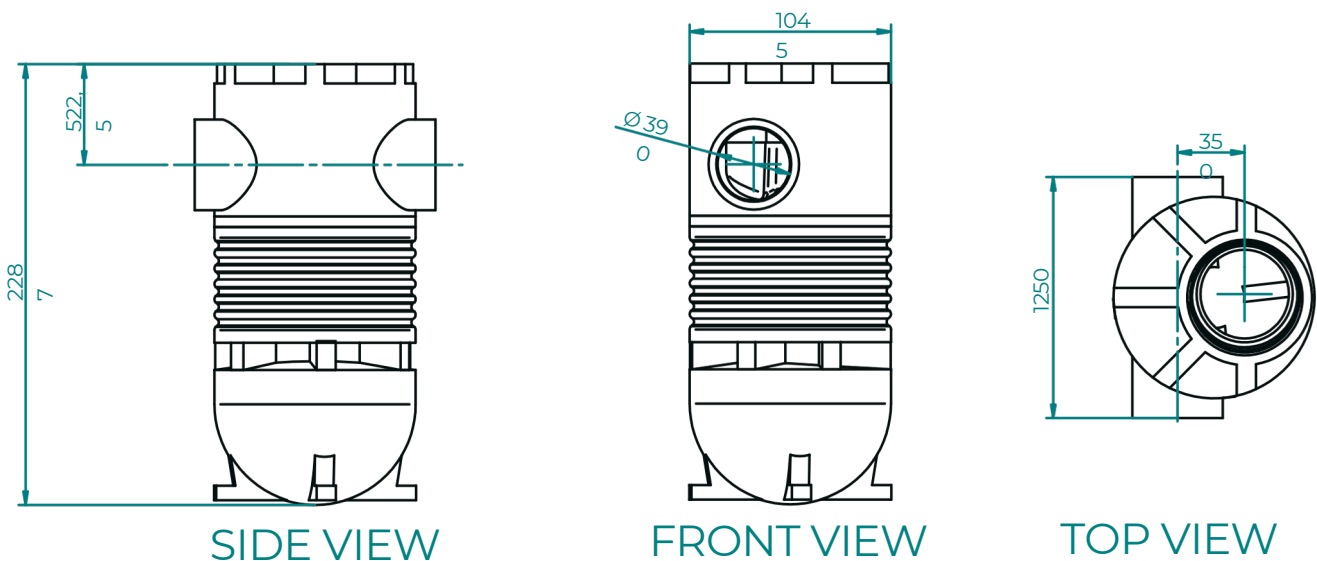

# EVERHARD GPT - CDS (NIPPER)

## INSTALLATION MANUAL

Excavations should be not less than 1400mm diameter and allow for a depth of 1700mm below the invert of the horizontal pipe entering the unit. Depth from the surface to the pipe invert will depend upon site conditions and the final surface level of the completed installation. Everhard normally recommends a maximum depth from surface to pipe invert of 2600mm.

Pipe connection entries in the cap are closed with moulded membranes which can be cut to suit the required pipe size with a power or hand-held jig-saw. These entries are hollow walled with an internal diameter to accept pipes up to 375 outside diameter.

For pipes of this size, such as 375 PE Pipe, the flat membrane is cut away and the pipe is pushed into the opening. Cutting away the inner wall of the moulded boss allows the insertion of any kind of pipe with outside diameters up to 455mm diameter. After cutting away the wall, the pipe is pushed into the opening.

Apply a full bead of silicone sealant to fill gaps around the external perimeter of any pipe connection. Alternatively, an external band or sleeve may be used to locate the pipe on the moulded boss. A bandage wrapped around the connection can be used to protect the sleeve.

Smaller pipes may be fitted by inserting the pipe through a hole of appropriate size cut in the membrane, so that the pipe intrudes by about 20mm, and sealing the joint. The pipe invert should always be at the lowest possible level in the membrane.

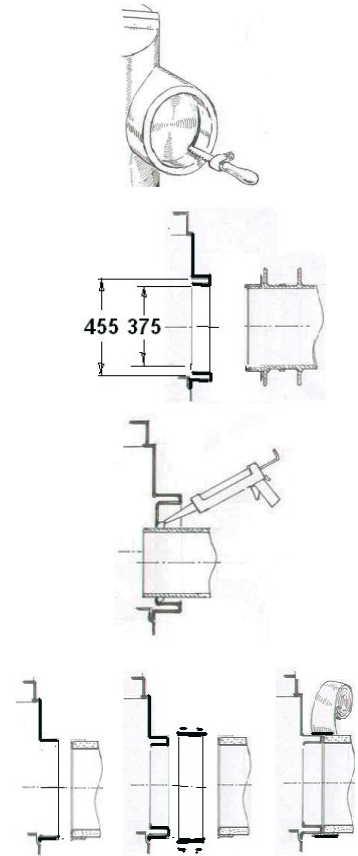

## NON-TRAFFIC SITUATIONS

If the installation will not be exposed to vehicular traffic of any kind, and pedestrian traffic will be limited, a light polymer access cover and polymer mounting flange may be sufficient. The flange is fitted directly to the top of the unit access port, or upper end and secured with six stainless steel screws. The access cover is similarly secured to the flange.

Where regular pedestrian traffic will be encountered, a cast-iron Class A or B Cover and Frame should be used. Where there is no exposure to vehicular traffic, the Assembled unit may not require any supporting or surrounding structure, other than a simple concrete collar.

### Installation of Non-Trafficable Everhard GPT - CDS (Nipper)

- / Excavation should be at least 1400mm diameter for unit adjustment during installation. See
- / 'INSTALLATION CONSIDERATIONS' section to determine depth.
- / Place bedding sand 150mm thick into the excavation and compact well.
- / Using a webbing sling, as described above, position the assembled unit.
- / Align Inlet port with the upstream pipe, and outlet port with the downstream pipe.
- / After connecting the pipes, and fitting the Universal Riser (if required), fill the unit with clean, fresh water before backfilling the excavation with a soil/sand mixture. For best results, cement powder may be added to stabilise the mass. No rubbish, debris, or stones larger than 10mm, should be present.
- / Fit whichever access cover arrangement is appropriate.
- / The backfill should be brought up to the invert of the pipes while being moderately compacted, ensuring that the rounded base of the collection module is fully enveloped.
- / Backfill the remainder of the excavation at the same time as the pipe trenches are filled, ensuring that the pipes are supported and will not tend to deform the entry ports or connections.
- / Backfill may be continued up to the required level to provide the base for any paving around the access cover. Moderately compact the backfill and any bedding layer required for paving.

# EVERHARD GPT - CDS (NIPPER)

## INSTALLATION MANUAL

### TRAFFICABLE SITUATIONS

When exposed to vehicular or regular pedestrian traffic suitable concrete or masonry support structure, such as an Everhard precast concrete chamber is required. In order for the support structure to be considered trafficable a Class C or D Cast-Iron cover and frame must be used, either directly over the access port or the Universal Riser and then be encased in poured concrete. In some cases, precast Everhard concrete Top Slabs with overhung edges may be appropriate. These may have either a plain hole for a top mounted access cover and frame, or cast-in cover and frame. Check with local authorities for any specifications that may be required.

### Installation of Trafficable Everhard GPT - CDS (Nipper)

- / An excavation not less than 1500mm diameter is needed to allow adjustment.
- / A 150mm thick reinforced concrete floor, compacted and leveled, is poured. Alternatively, a precast slab may be used.
- / An enveloping supporting shaft is required to contain and protect the CDS® Nipper unit, such as an Everhard precast concrete chamber shaft (1220mm inside diameter). This will also transmit applied wheel loads down to the base slab without them being carried by the CDS® Nipper itself. The support structure should be set on a bed of mortar or epoxy compound on the concrete base.
- / Using a webbing sling, choke hitched around the body and stub connections, lower the assembled unit into the chamber shaft. Align the inlet port with the upstream pipe and the outlet port with the downstream pipe.
- / After connecting pipes, an Everhard precast 'Nipper chamber collar' can be placed over the shaft on a bed of mortar or epoxy, with the moulded saddle openings over the pipes.
- / Continue putting the support structure shaft over the chamber collar to reach the underside of the selected top slab arrangement and allow the top of the access cover to match the final surface level.
- / Fill the unit with clean, fresh water to assist in stabilising the unit.
- / Pack the space between the unit and the concrete chamber with bedding sand, lightly compacted (approximately 0.3m<sup>3</sup> or 500kg per metre of chamber depth).
- / Backfill outside the support structure, and around any fitted riser (same as the non-traffic installations).

### OPERATION AND MAINTENANCE

The CDS® Nipper is designed to provide cost-effective and efficient removal of gross pollutant matter from storm water flow, and may be used for similar functions in trade waste and other waste water applications.

- / The incoming water is directed into and around a circular weir in the upper module, and is then directed down inside the Vortex Chamber.
- / The Vortex Chamber has a perforated stainless steel screen which allows water to pass through into an outer chamber, while retaining waste matter.
- / The 'clear' water is directed up through an opening into the upper module where it passes through the outlet and continues downstream.
- / Trapped wastes collect in the hemispherical bottom chamber.
- / Opening the top cover allows direct access down into the bottom chamber so that the standard suction leg of a maintenance/pump-out cleaning vehicle can be lowered into the unit and collected waste simply and easily removed.



# EVERHARD GPT - CDS (NIPPER)

## INSTALLATION MANUAL

### CAUTION!

THE INTERIOR OF A NIPPER GROSS POLLUTANT TRAP IS A CONFINED SPACE!  
ENTRY FOR ANY PURPOSE IS **NOT RECOMMENDED** WITHOUT FULLY DETAILED  
WORK INSTRUCTIONS IN PLACE AND IN EFFECT  
FULL SAFETY PRECAUTIONS **MUST** BE TAKEN  
PROTECTIVE CLOTHING AND BREATHING APPARATUS MAY BE NECESSARY  
**TRAINED PERSONNEL ONLY** SHOULD ENTER THE UNIT

---