

**Product Name:**  
4000L Septic Tank

**EI Code:**  
87210 - without partition  
87211 - with partition

**Dimensions:**  
2335 H x 1880 D

**Weight:**  
201kg - without partition  
211kg - with partition

**Material:**  
PP

**Warranty:**  
15 Years

### Additional Information:

It is a **legal requirement** that all domestic septic tanks over 2050L in NSW & VIC be installed with a partition. Larger capacity collection wells available using multiple tanks.



Product Code	Description	Weight kg	A Overall Height	B Liquid Level	C Tank Rim to Invert of Outlet	D Under Roof to Invert of Outlet	E Maximum Cover to Inlet Pipe	F Diameter at Top	G Maximum Cover to Outlet Pipe
87210	4000L Septic Tank with no partition	201	2335	1845	225	475	325	1880	375
87211	4000L Septic Tank with partition	210	2335	1845	225	475	325	1880	375

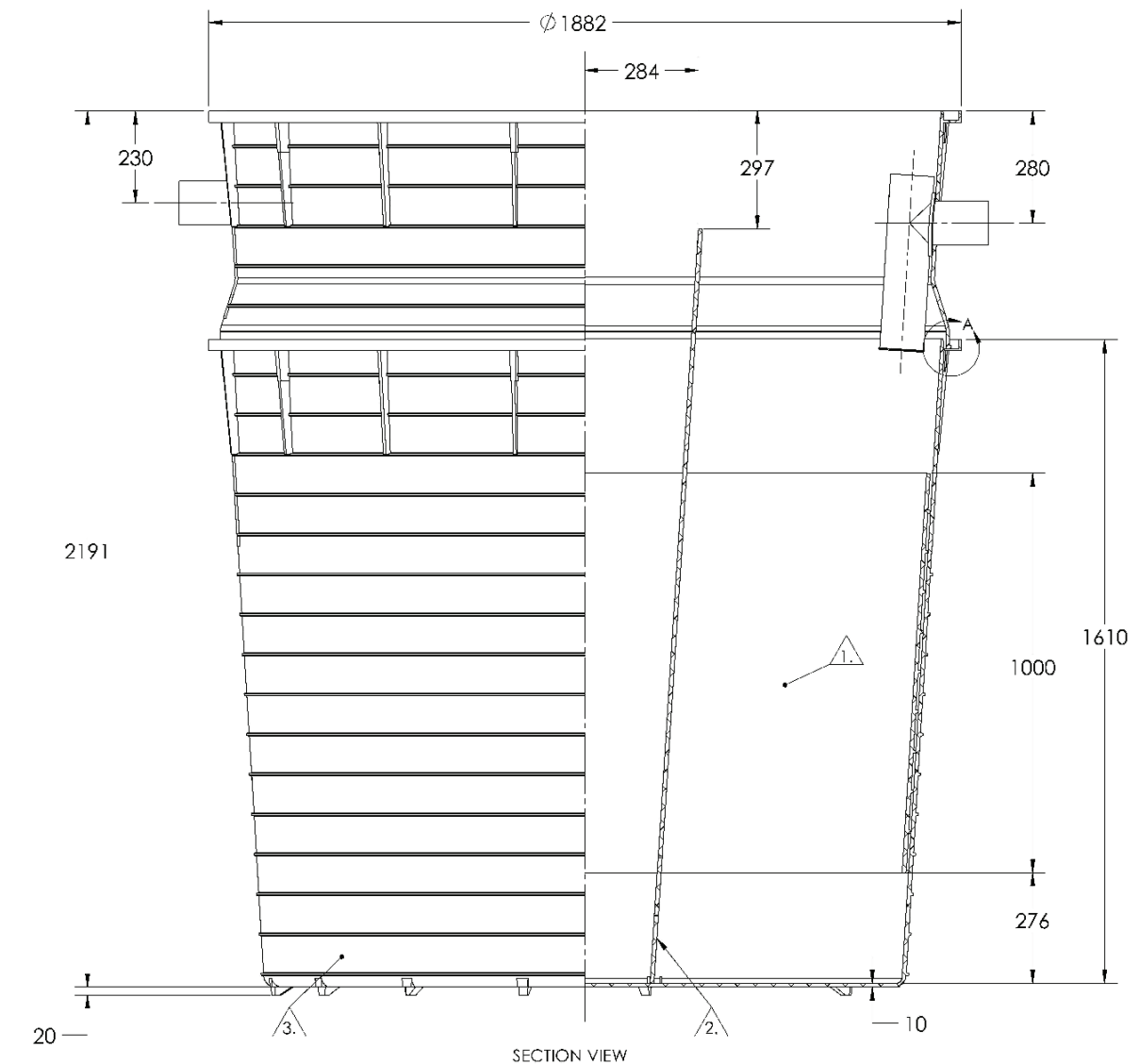

- 1. TANK REINFORCING SUPPLIED INSTALLED IN TANK AND PRESSED DOWN INTO POSITION SO THAT BOTTOM EDGE OF RING IS APPROX. 275mm ABOVE THE FLOOR LEVEL
- 2. CORFLUTE PARTITION TO DIVIDE TANK INTO 2:1 RATIO (INLET SECTION/OUTLET SECTION)
- 3. STANDARD 3000L NOMINAL CAPACITY POLY SEPTIC TANK AS SHOWN ON DWG P-TNK87010. REFER TO DRAWING FOR ALL DETAILS
- 4. TANK EXTENSION BELLED TO CORRECT DIAMETER USING HEAT BATH AND MANDREL
- 5. HOT AIR WELD TO SEAL JOINT
- 6. REAR OF JOINT SEALED BY HOT AIR WELDING

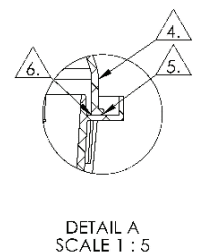

Disclaimer: All measurements are in millimetres and are subject to change without any prior notice. It is advised for this product to be installed by a professional contractor to ensure installation is correct. Further information is available at [www.everhard.com.au](http://www.everhard.com.au)

\*Drawing is without lid on top of septic tank